

## *ACION 3422 4 Driven-Output Forward and Reverse Segmentable Optical Node 1002 MHz*

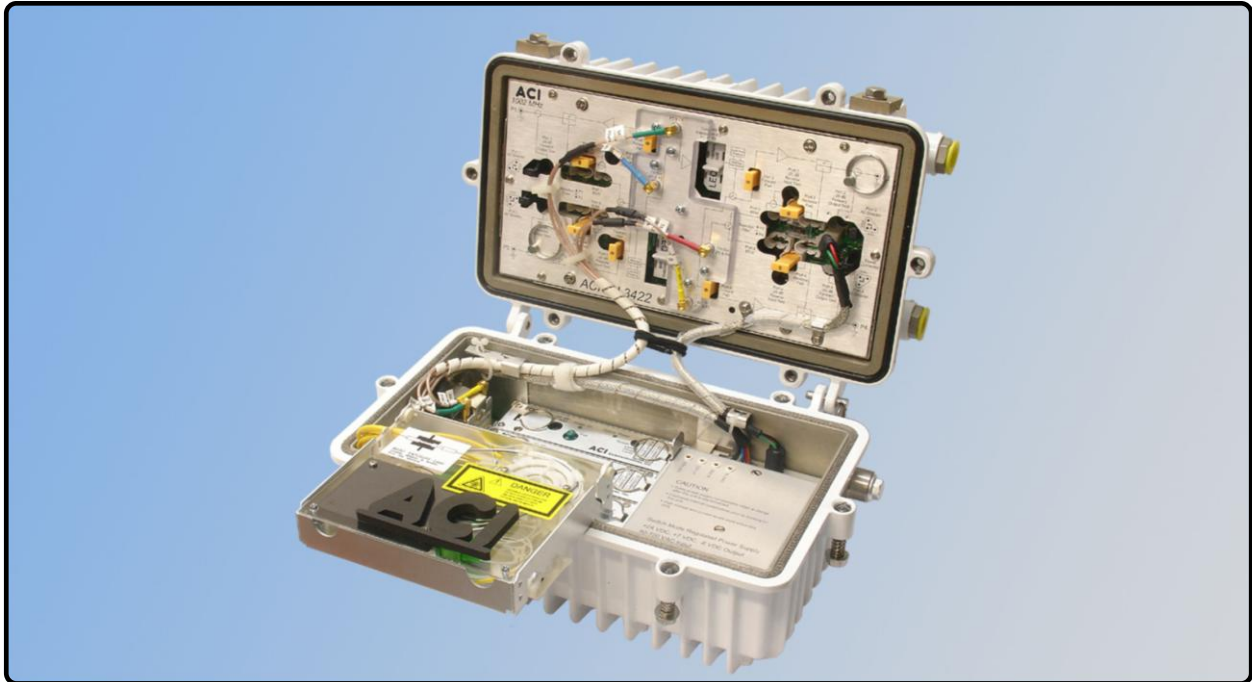

The ACION 3422 is a 4 output 2X2 fully segmentable 1002 MHz node that is ideal for HFC or fiber deep architectures.

### Features

- Four driven output ports
- -20.0 dB directional coupler test points
- 15 amp power passing
- Plug-in bridger switching for managing the reverse path @ 0, -3.0, -6.0, -12.0 dB and open with active status monitoring (optional)
- Reverse path -20.0 dB test points for each port
- Separate attenuator control for each reverse path
- FP, DFB and CWDM transmitters available
- Redundant receiver (optional 1:4 only)
- Redundant transmitter (optional 4:1 only)
- Plug-in equalizers and pads
- Plug-in surge protection sidactor
- Plug-in forward and reverse configuration modules allows for easy field reconfiguration to add or remove segmentation as needed
- 85% efficient 40/90 VAC switch-mode power supply with built-in Triac surge protection
- Standard push on "F" connectors can be used on all test points
- Compact size
- Future availability of an 85/105 MHz option that will double the reverse band width

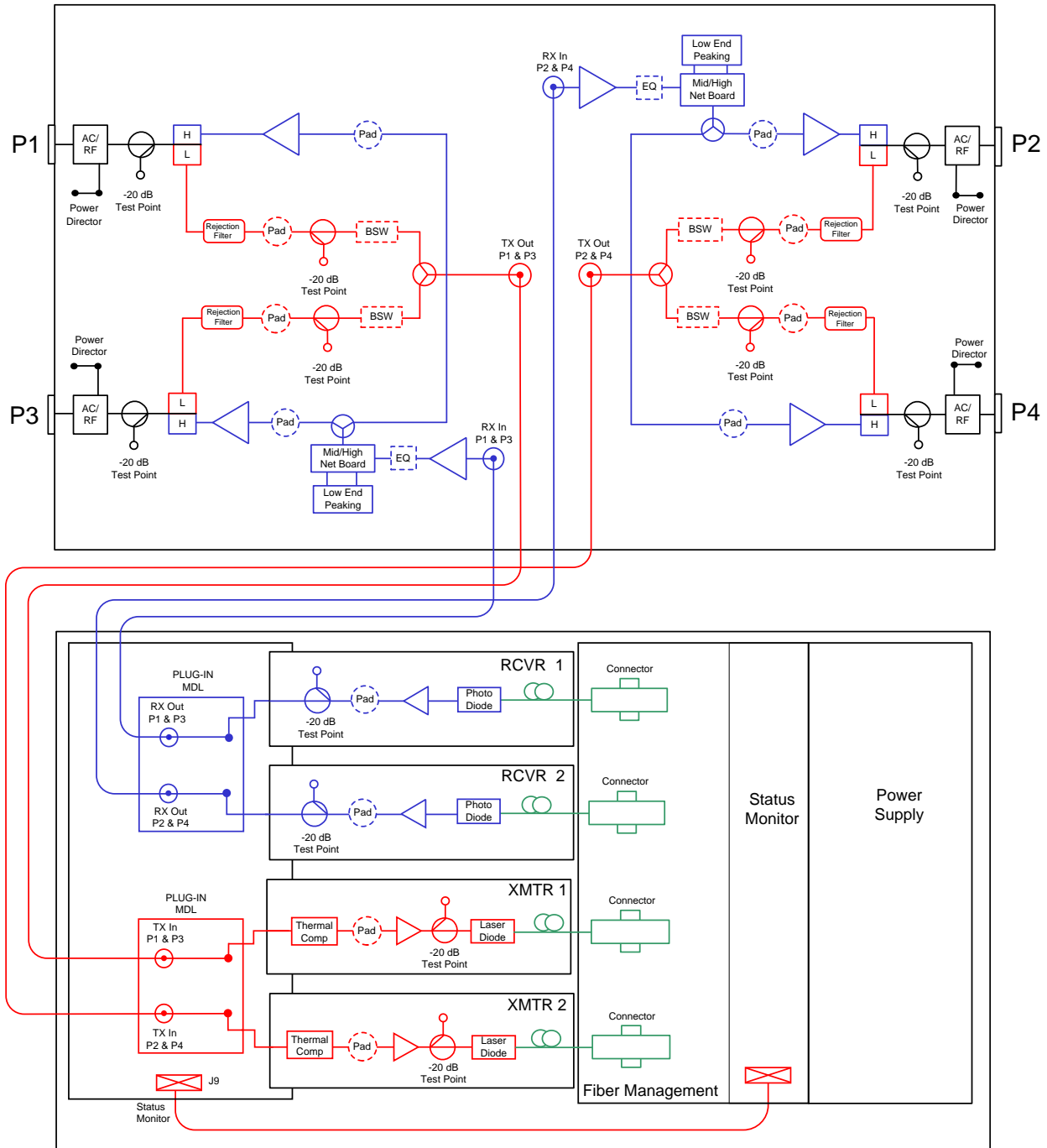

ACION 3422 Block Diagram (Forward and Reverse Segmented Optical Node 1002 MHz)

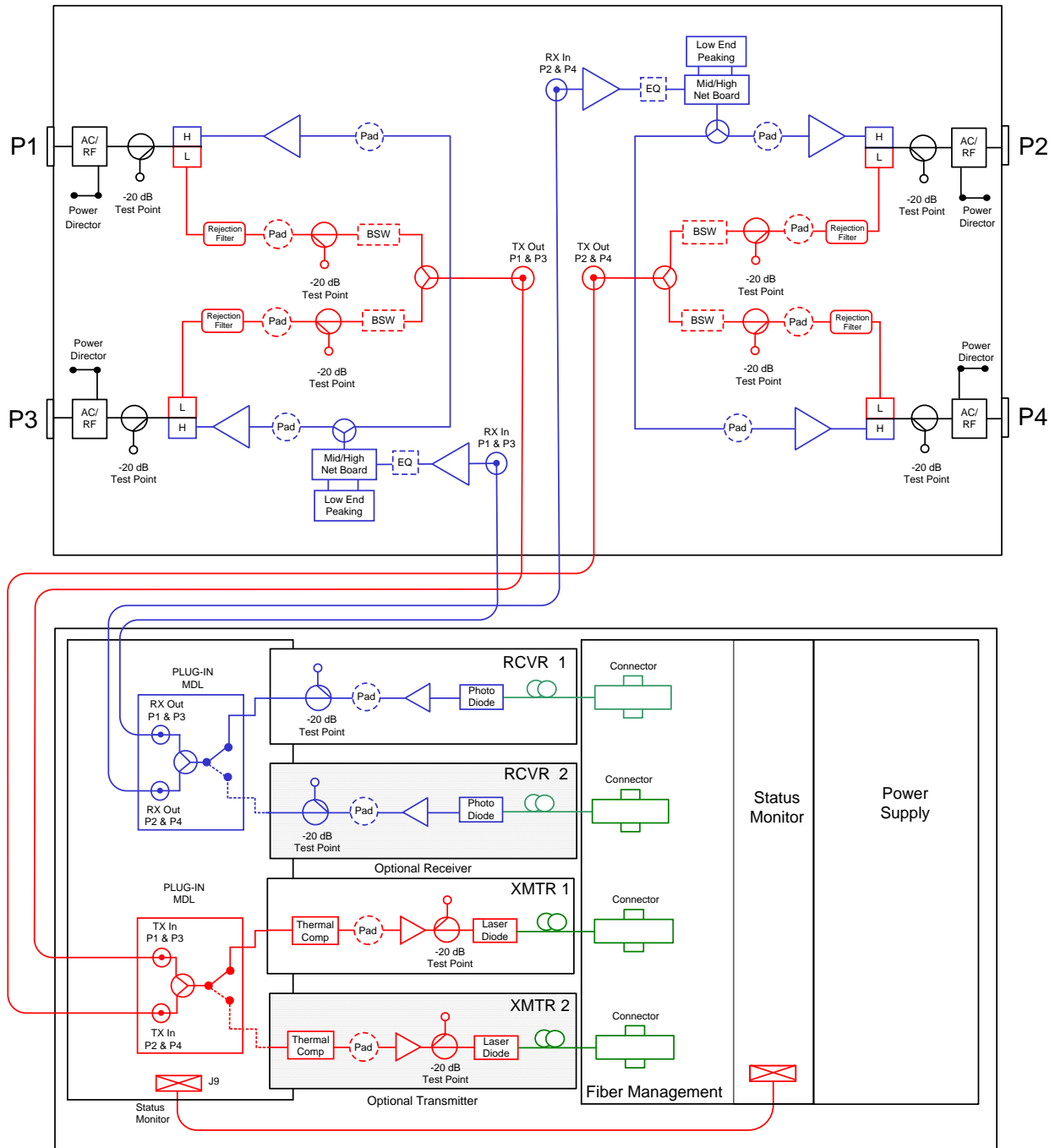

ACION 3422 Block Diagram (Non-Segmented Optical Node 1002 MHz)

**ACI Communications, Inc.** ACION 3422 4-Output  
( Forward and Reverse Segmentable Optical Node 1002 MHz)

**STATION PARAMETERS**

	CONDITIONS	UNITS	SPECIFICATION			NOTES
Housing passband		MHz	5 to 1002			
Input current capacity	Any port, worst case	Amperes	15			
Frequency range		MHz	5 - 10	11-750	751 - 1002	
Hum modulation	Time domain @ rated current above	-dBc	55	70	65	
Station passband		MHz	54 to 1002			
Return loss- Ports 1 to 4	Worst case	-dB	16.5			Typical 18.0
Frequency range		MHz	54-870	871-1002		
Port to Port Isolation	Typical	-dB	70	60		

**Test Points**

Test point type	Directional coupler	N / A	DC			
Test point level(s)		-dB	20.0			
Test point accuracy	Forward TP	±dB	0.5			
Frequency range	Reverse TP	MHz	5 to 40			
Test point accuracy	Reverse TP	±dB	0.5			

**Frequency Range**

Station passband		MHz	54 to 1002			
Station flatness - feeder out		±dB	0.75			

**Station Gain**

			Minimum	Maximum	
Configuration			1:4	1:2 (X2)	
Gain - feeder	@ 1002 MHz	dB	33	37	
Gain control type		N / A	Plug-in pads		
Gain control range		dB	15.0		
Gain control steps	Pad value steps	dB	0.5		

**Station Slope**

Slope control type	Linear equalizers	dB	Plug-in Equalizers		
Slope control range		dB	-12.0 to +13.0		
Slope control steps	Equalizer value steps	dB	1.0 linear steps		

**Operational Specifications**

Operational level - feeders	@ 1002 MHz	dBmV	52.2			
Operational slope	@ 54 / 550 / 750 / 870 / 1002 MHz	dB	0 / 9.0 / 12.6 / 14.8 / 17.2			
Operational optical input range		dBm	-3 to +2			Recommended optical input level 0 dBm

**Station Output Levels with a -3 dBm optical input**

Distribution out	@ 54 / 550 / 750 / 870 / 1002 MHz	dBmV	35.0 / 44.0 / 47.6 / 49.8 / 52.2		
------------------	-----------------------------------	------	----------------------------------	--	--

**Station Noise Figure - values for RF portion of node only. Complete values dependent on optical link.**

			* No slope	17.2 dB slope	* LEQ1= 0 dB
Noise figure (NF)	@ 54 MHz	dB	9.5	16.0	
Noise figure (NF)	@ 550 MHz	dB	9.5	11.0	
Noise figure (NF)	@ 1002 MHz	dB	9.5	11.0	

**Station Distortions - values for RF Portion of node only. Complete values dependent on optical link.**

**550 MHz analog channel loading, 79 channels + 450 MHz digital channel loading, 256 QAM at -6 dBc relative to its associated visual carrier**

Reference levels	@ 54 / 550 / 650 / 870 / 1002 MHz	dBmV	35.0 / 44.0 / 47.6 / 49.8 / 52.2		
		N / A	Worst Case	Typical	
Composite Triple Beat (CTB)		-dBc	70	72	
Cross Modulation (XMOD)		-dBc	64	66	
Composite Second Order (CSO -)	(Vc +0.75 & -1.25 MHz only)	-dBc	69	71	
Composite Second Order (CSO +)	(Vc +1.25 MHz only)	-dBc	69	71	
CIN		-dBc	65	67	

**Station Group Delay**

Group delay	Channel 2 (std)	nSec / 3.58 MHz	30		Typical 25
Group delay	Channel 3	nSec / 3.58 MHz	16		
Group delay	Channel 4	nSec / 3.58 MHz	10		
Group delay	Channel 5 & >	nSec / 3.58 MHz	3		

ACI Communications, Inc.			ACION 3422 4-Output ( Forward and Reverse Segmentable Optical Node 1002 MHz)		
REVERSE SPECTRUM:					
	CONDITIONS	UNITS	SPECIFICATIONS		NOTES
Reverse - General					
Station passband		MHz	5 to 42		
Station flatness		±dB	1.0		
Bridger switch control (optional)		-dB	0, 3.0, 6.0, 12.0 & open		
Port to Port Isolation	Typical	-dB	65		
Reverse - Station Gain (RF section only)					
Configuration			4:1	2:1 (X2)	
Gain	Minimum	dB	*10.0	6.0	*for one TX Configuration
Gain control type		N / A	Plug-in pads		
Gain control steps	Pad value steps	dB	0.5		
Reverse - Station Input Levels					
RF station input to node for 40 dBmV @ Laser TP	Minimum	dBmV	17		
Reverse - Noise Figure					
Configuration			4:1	2:1 (X2)	
Station Noise Figure (w/EQ)		dB	16.5	12.0	
Reverse - Station Distortions @ 23 dBmV					
Composite Second Order (CSO)	6 NTSC channel loading	-dBc	75		
Composite Triple Beat (CTB)	6 NTSC channel loading	-dBc	80		
Cross Modulation (XMOD)	6 NTSC channel loading	-dBc	80		
Noise-to-Power Ratio (NPR)	Noise loading	dB	Typical >40.0 / 13.0		@ 10.0 dB optical loss (6.0 dB fiber +4.0 dB flat loss) @ -51 dBmV/Hz
Reverse - Station Group Delay					
Group delay	5 MHz	nSec / 1.5 MHz	36		
Group delay	7 MHz	nSec / 1.5 MHz	16		
Group delay	10 MHz	nSec / 1.5 MHz	4		
Group delay	35 MHz	nSec / 1.5 MHz	8		
Group delay	38.5 MHz	nSec / 1.5 MHz	25		
Power Requirements:					
Station configuration (Over temperature range of -40°F to +140°F (-40°C to +60°C) @ 90 VAC)			1X4 (1RX & 1TX)	2X2 (2RX & 2TX)	
Power requirements	Worst case	W	67.5	79.8	
AC Voltage					
Input ranges		VAC	40 - 90		
Current Draw					
@ 40 VAC	Maximum	A	1.97	2.28	
@ 50 VAC	Maximum	A	1.66	1.90	
@ 60 VAC	Maximum	A	1.43	1.64	
@ 70 VAC	Maximum	A	1.30	1.48	
@ 80 VAC	Maximum	A	1.18	1.33	
@ 90 VAC	Maximum	A	1.05	1.22	
Environmental					
Operating temperature		°F (°C)	-40 to +140 (-40 to +60)		
RF output stability over temperature		±dB	0.5		
Physical					
Dimensions (H X W X D)		In. (cm)	6.75 X 14.25 X 9 (17.15 X 36.20 X 22.86)		
Weight		lbs. (kg)	18.25 (8.28)		

## ACION 3422 Configuration Sheet

Customer: \_\_\_\_\_

Created By: \_\_\_\_\_ Order Date: \_\_\_\_\_

### ORDERING MATRIX

January 10, 2012

Position	1	2	3	4	5	6	7	8	9	10	11	12	13	14	15
<b>PART NUMBER</b>	<b>3</b>	<b>N</b>												<b>0</b>	

- 3  **BASIC CONFIGURATION**  
 A = FWD 1:4 REV 4:1 nonsegmented  
 1 Transmitter installed  
 1 Receiver installed  
 TX and RX redundancy capable  
 B = FWD 1:4 REV 2:1 (X2) Reverse segmented  
 2 Transmitters installed  
 1 Receiver installed  
 RX redundancy capable  
 C = FWD 1:2 (X2) REV 4:1 Forward segmented  
 1 Transmitter installed  
 2 Receivers installed  
 TX redundancy capable  
 D = FWD 1:2 (2X) REV 2:1 (X2) Forward & Return segmented  
 2 Transmitters installed  
 2 Receivers installed  
 Not TX or RX redundancy capable
- 4  **DIPLEX FREQUENCY SPLIT**  
 4 = 42/53  
 5 = 55/70  
 6 = 65/85  
 8 = 85/105 (Future)
- 5  **OPTICAL CONNECTOR TYPE**  
 1 = SC/APC (Standard)  
 2 = SC/UPC  
 3 = FC/APC  
 4 = FC/UPC
- 6  **TRANSMITTER 1 - Primary 4:1 or Ports 1 & 3 for 2:1 (X2)**  
 7  **TRANSMITTER 2 - Secondary 4:1 or Ports 2 & 4 for 2:1 (X2)**
- TYPE FP & DFB**  
 0 = None  
 D = Uncooled 1310 nm 1.0 mW FP  
 H = Uncooled 1310 nm 2.0 mW FP W/ISOLATOR  
 J = Uncooled 1310 nm 1.0 mW DFB  
 R = Uncooled 1310 nm 2.0 mW DFB  
 B = Uncooled 1310 nm 3.0 mW DFB  
 C = Uncooled 1550 nm 2.0 mW DFB
- TYPE DFB CWDM**  
 A = Uncooled 1471 nm DFB CWDM (2.0 mW)  
 G = Uncooled 1491 nm DFB CWDM (2.0 mW)  
 V = Uncooled 1511 nm DFB CWDM (2.0 mW)  
 L = Uncooled 1531 nm DFB CWDM (2.0 mW)  
 W = Uncooled 1551 nm DFB CWDM (2.0 mW)  
 M = Uncooled 1571 nm DFB CWDM (2.0 mW)  
 N = Uncooled 1591 nm DFB CWDM (2.0 mW)  
 T = Uncooled 1611 nm DFB CWDM (2.0 mW)  
 U = Uncooled 1431 nm DFB CWDM (2.0 mW) E-Band  
 Y = Uncooled 1451 nm DFB CWDM (2.0 mW) E-Band
- 8  **RECEIVER REDUNDANCY (Basic configuration A or B only)**  
 1 = Not redundant  
 2 = RX Redundant
- CWDM Mux/DeMux or WDM**  
**(For a 1X2 Mux or WDM use positions 9 & 11)**  
 9  CWDM or DWDM DeMux Downstream Wavelength # 1  
 10  CWDM or DWDM DeMux Downstream Wavelength # 2  
 11  CWDM Mux Upstream Wavelength #1  
 12  CWDM Mux Upstream Wavelength #2
- 0 = None  
 A = 1271 nm      K = 1451 nm      W = 1310 nm  
 B = 1291 nm      L = 1471 nm      Y = 1550 nm  
 C = 1311 nm      M = 1491 nm  
 D = 1331 nm      N = 1511 nm      **DWDM (Downstream Only)**  
 E = 1351 nm      P = 1531 nm      3 = 1290 nm  
 F = 1371 nm      R = 1551 nm      4 = 1291 nm  
 G = 1391 nm      T = 1571 nm      5 = 1293 nm  
 H = 1411 nm      U = 1591 nm      6 = 1295 nm  
 J = 1431 nm      V = 1611 nm
- 13  **HOUSING TYPE (See Note 1)**  
 P = Powder Coated (Complete Station)  
 K = Powder Coated (Upgrade kit without housing base)
- 14  **STATUS MONITORING**  
 0 = None  
 A = AM Communications (Future)  
 C = Cheetah (Tollgrade) (Future)
- 15  **CUSTOM**  
 0 = None  
 2 = Port 1 bypassed, Port 2 forward gain lowered by 10 dB  
 5 = 15 dB Slope at 1002 MHz  
 X = Determined by Product Management

### NOTES:

- 1 The ACION 3422 upgrade kit (option # 13 selection K) will include a fully configured optical top housing assembly and the RF module tray. The upgrade Kit will allow field upgrades of legacy ACION 3000 & ACION 3410 nodes or it can be used as a conversion kit to convert an existing SDA RF amplifier into a fully 2X2 segmentable optical node.

