

*ACION 1002 Series
1 or 2 Output Optical Node
1002 MHz*

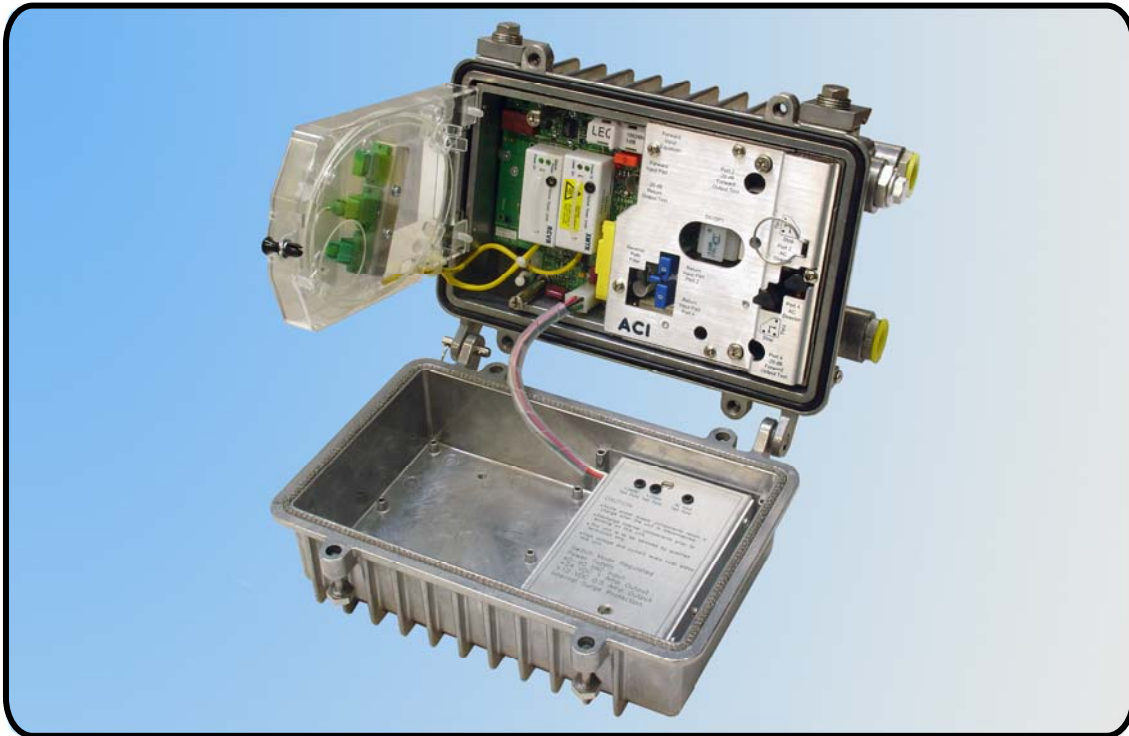

The ACION 1002 is a compact economically priced 1 or 2 output node that is ideal for use in HFC, fiber deep, MDU or business class services architectures. The node can be configured with either a FP, DFB or CWDM DFB reverse path transmitter.

Features

- One (1) driven output or two (2) split outputs
- Modular RF / optics section
- Plug-in pads and equalizers
- -20 dB directional coupler test points
- Optional redundant receiver
- FP, DFB and CWDM transmitters available
- 40 to 90 VAC (cable)
- 90 to 240 VAC (mains)
- 15 Amp power passing capacity (40 to 90 VAC only)

Benefits

- Economical price
- Compact size
- Up to 52.2 dBmV out at 1002 MHz on the single output version
- Ideal for HFC and passive architectures, or MDU applications
- Common plug-ins with other ACI nodes and amplifier products
- Configurable to your specific needs
- 85/105 MHz frequency option that will double the reverse bandwidth
- Plug-in location for reverse path rejection filter (sold separately)

ACION 1002
1002 MHz One [1] Driven Output or Two [2] Split Output Optical Nodes

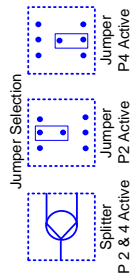
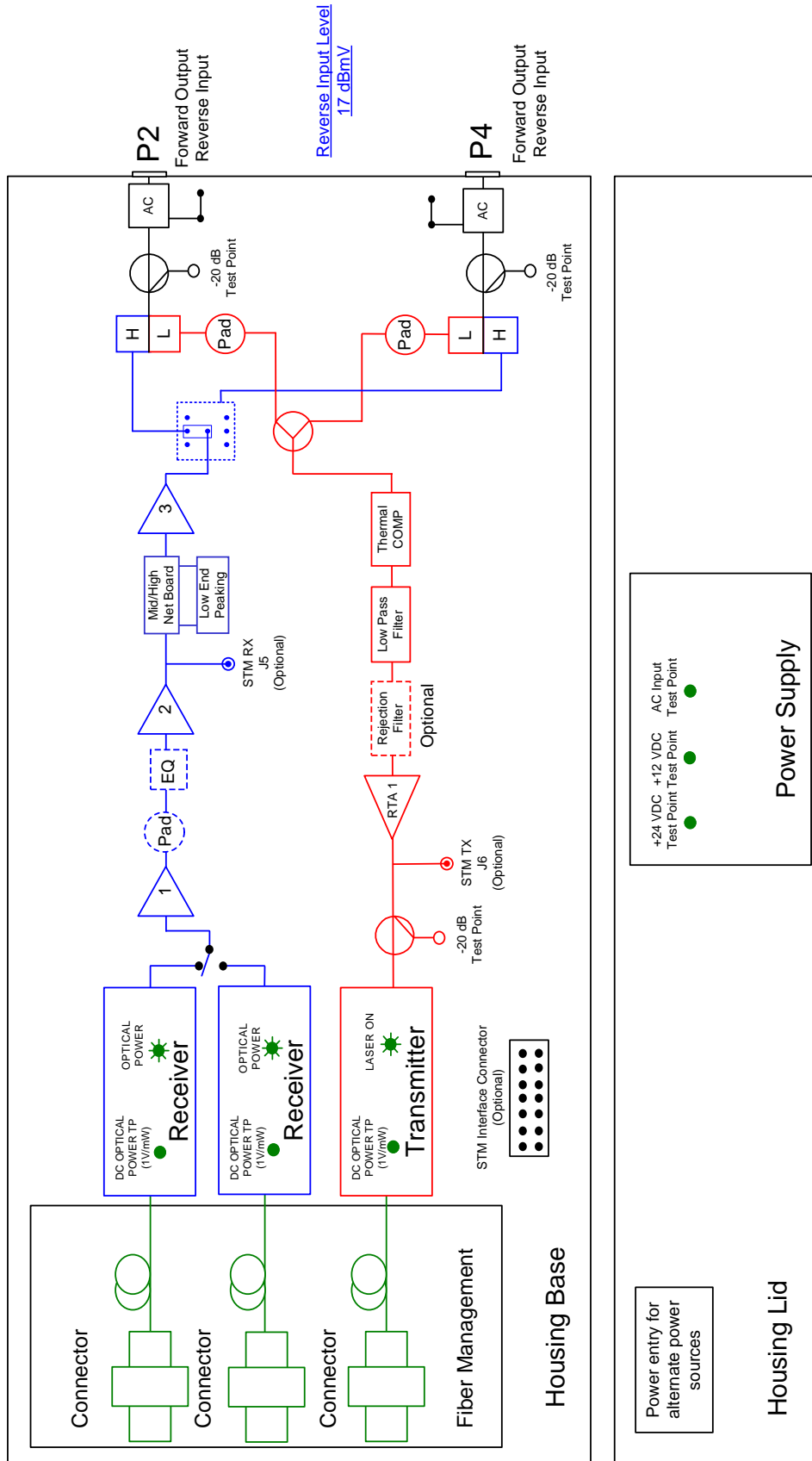

ACI Communications, Inc.			ACION 1002 Optical Node 1002 MHz (One [1] Driven Output or Two [2] Split Outputs)		
STATION PARAMETERS:					
	CONDITIONS	UNITS	SPECIFICATION	NOTES	
Housing passband		MHz	5 to 1002		
Input current capacity	Any port, worst case	Amperes	15	Cable power only (40-90 VAC)	
Frequency range		MHz	50 - 1002		
Hum modulation	Time domain @ 0 AMPS	-dBc	70	Cable power only (40-90 VAC)	
Hum modulation	Time domain @ 12 AMPS	-dBc	70	Cable power only (40-90 VAC)	
Hum modulation	Time domain @ 15 AMPS	-dBc	65	Cable power only (40-90 VAC)	
Test Points					
Test point type	Directional coupler	N/A	DC		
Test point level(s)		-dBc	20		
Test point accuracy	Forward TP	±dB	0.5		
Test point accuracy	Reverse TP	±dB	0.5		
RF Station					
Station passband		MHz	54 to 1002		
Return loss	Worst case	-dB	17	18 Typical	
Station flatness - feeder out		±dB	0.75		
Gain: 1 output / 2 outputs	@ 1002 MHz Minimum	dB	45.0 / 42.0		
Output stability		dB	1.5		
Gain control type			Plug-in pads		
Gain control range		dB	15		
Gain control steps	Pad value steps	dB	0.5		
Slope control type	Linear equalizers	dB	Plug-in EQ's		
Slope control range		dB	-21.0 to +13.0		
Slope control steps	Equalizer value steps	dB	1.5		
Operational Specifications with a -2 dBm optical input					
Operational level	@ 1002 MHz	dBmV	52.2	48.7 dBmV for split version	
Operational slope	@ 54 / 550 / 750 / 870 / 1002 MHz	dB	35.0 / 44.0 / 47.6 / 49.8 / 52.2		
Optical input range	Typical	dBmV	-3 to +2		
Station Output Levels					
Distribution out	@ 54 / 550 / 750 / 870 / 1002 MHz	dBmV	35.0 / 44.0 / 47.6 / 49.8 / 52.2	Split 31.5 / 40.5 / 44.1 / 46.3 / 48.7	
Station Noise Figure - values for RF portion of node only. Complete values dependent upon link.					
Noise figure (NF)	@ 54 MHz	dB	4.1		
Noise figure (NF)	@ 550 MHz	dB	5.1		
Noise figure (NF)	@ 1002 MHz	dB	6.2		
Station Distortions with Link					
550 MHz analog channel loading, 79 channels +450 MHz digital channel loading 256 QAM at -6 dBc relative to its associated visual carrier					
			Worst Case	Typical	
Composite Triple Beat (CTB)		-dBc	76	78	
Composite Second Order (CSO -)	(Vc +0.75 & -1.25 MHz)	-dBc	67	69	
Composite Second Order (CSO +)	(Vc +1.25 MHz only)	-dBc	75	77	
Cross Modulation (XMOD)		-dBc	74	76	
Carrier-to-Intermodulation Noise (CIN)		-dBc	74	76	
Station Group Delay					
Group delay	Channel 2 (Std)	nSec / 3.58 MHz	25		
Group delay	Channel 3	nSec / 3.58 MHz	16		
Group delay	Channel 4	nSec / 3.58 MHz	10		
Group delay	Channel 5 & >	nSec / 3.58 MHz	3		

Confidential

Information contained in this document is subject to change without notice.

Revision Date: 03/29/11

ACI Communications, Inc.			ACION 1002 Optical Node 1002 MHz (One [1] Driven Output or Two [2] Split Outputs)		
REVERSE SPECTRUM:					
Reverse - General		CONDITIONS	UNITS	SPECIFICATION	NOTES
Station passband			MHz	5 to 42	
Station flatness		Peak-to-valley	dB	1.0	
Output stability			±dB	0.75	
Return loss		Worst case	-dB	17	18 Typical
Reverse - Station Gain					
Gain		+1, -0	dB	18	
Gain control type			N / A	Plug-in pads	
Gain control range			dB	12	
Gain control steps		Pad value steps	dB	0.5	
Reverse - Station Output Levels					
@ Input to transmitter		Typical	dBmV	40	With 17 dBmV at housing port
Reverse - Noise Figure					
Station noise figure			dB	10.5	
Reverse - Bit Error Rate					
Bit error rate		QPSK (1.5 Mbps)	BER	≤10 ⁻⁶	
Reverse - NPR					
Noise-to-Power Ratio (NPR)		Noise loading	dB	Typical >35 / 18	@ 10.0 dB optical loss (6.0 dB fiber +4.0 dB flat loss) @ -52.2 dBmV/Hz
Reverse - Station Group Delay					
Group delay		5.5 MHz	nSec / 1.5 MHz	36	
Group delay		10.0 MHz	nSec / 1.5 MHz	16	
Group delay		33.5 MHz	nSec / 1.5 MHz	7	
Group delay		38.5 MHz	nSec / 1.5 MHz	5	
Power Requirements: For cable powered 40-90 VAC					
Station configuration		1RX + 1TX over temperature range of -40 to +140 °F (-40 to +60 °C)			
Power requirements		Worst case	W	25.4	
AC Voltage					
Input ranges			VAC	40 - 90	
Current Draw (Cable powered 40-90 VAC)					
@ 40 VAC		Maximum	A	0.95	
@ 50 VAC		Maximum	A	0.79	
@ 60 VAC		Maximum	A	0.69	
@ 70 VAC		Maximum	A	0.63	
@ 80 VAC		Maximum	A	0.58	
@ 90 VAC		Maximum	A	0.54	
Environmental					
Operating temperature			°F (°C)	-40 to +140 (-40 to +60)	
Physical					
Dimensions (H X W X D)			in. (cm)	5.8 X 9.25 X 5.94 (14.73 X 23.50 X 15.10)	
Weight			lbs (kg)	8.7 (3.95)	

Confidential
Information contained in this document is subject to change without notice.
Revision Date: 03/29/11

ACI Communications, Inc.			ACION 1002 Optical Node 1002 MHz DFB & FP Transmitter Specifications						NOTES
GENERAL	CONDITIONS	UNITS	TRANSMITTER SPECIFICATIONS						NOTES
TRANSMITTER MODEL NUMBER			090607-01XXX 3.0 mW	090607-02XXX 2.0 mW	090607-03XXX 1.0 mW	090606-02XXX 2.0 mW W/Isolator	090606-04XXX 1.0 mW	090606-05XXX 1.0 mW W/Isolator	WHERE XXX= CONNECTOR TYPE
Laser type		N/A	Uncooled DFB	Uncooled DFB	Uncooled DFB	Fabry-Perot FP	Fabry-Perot FP	Fabry-Perot FP	
Optical connector		N/A	SC/APC, SC/UPC, FC/APC, FC/UPC						
Operating bandwidth		MHz	5-200						
Optical wave length		nm	1310 ±20	1550 ±20	1310 ±20	1310 ±20	1310 ±20	1310 ±20	
Optical power test point		V/mW	1.0 / 1.0						
Optical power range		mW	2.8-3.2	2.0 min	1.0 Min	2.0 min	1.0 Min	1.0 Min	At 25 °C
Laser ON/OFF status indicator		-dBmV	3						Relative to initial optical power at 25 °C
RF impedance		Ohms	75						
Peak-to-valley frequency response		dB	1.0						Over operating bandwidth
Operational temperature		°F (°C)	-40 to +140 (-40 to +60)						
DISTORTIONS									
Input level		dBmV	40						
Level repeatability		±dB	1.0						Maximum receiver RF level variation between transmitters
Return loss	Worst Case	-dB	10.0	10.0	10.0	9.0	9.0	9.0	
Single tone CNR		dB	60	55	55	50	45	45	CNR in 4 MHz bandwidth 19 dBmV @ input to station, using A8KQRR receiver
DTO (FP) CTB (DFB)	Worst Case	-dBc	53	55	55	51	65	65	Test uses 2T channels T12-T13 (FP) or 4T channels T9-T13 (DFB), using A8KQRR receiver
DSO (FP) CSO (DFB)	Worst Case	-dBc	54	51	51	53	65	65	Test uses 2T channels T12-T13 (FP) or 4T channels T9-T13 (DFB), using A8KQRR receiver

Confidential
 Information contained in this document is subject to change without notice.
 Revision Date: 3/29/11

ACI Communications, Inc.			ACION 1002 Optical Node 1002 MHz DFB CWDM Transmitter Specifications								
GENERAL	CONDITIONS	UNITS	TRANSMITTER SPECIFICATIONS								NOTES
TRANSMITTER MODEL NUMBER			090646-01XXX	090646-02XXX	090646-03XXX	090646-04XXX	090646-05XXX	090646-06XXX	090646-07XXX	090646-08XXX	WHERE XXX= CONNECTOR TYPE
Optical wave length		nm	1471	1491	1511	1531	1551	1571	1591	1611	±1.5 nm @ 25° C
Optical power range	Minimum	mW	2.0	2.0	2.0	2.0	2.0	2.0	2.0	2.0	
Laser type		N/A	Uncooled DFB (CWDM)								
Optical connector		N/A	SC/APC, SC/UPC, FC/APC, FC/UPC								
Operating bandwidth		MHz	5-200								
Optical power test point		V/mW	1.0 / 1.0								
Laser ON/OFF status indicator		-dBmV	3								Relative to initial optical power at 25° C
RF impedance		Ohms	75								
Peak-to-valley frequency response		dB	1.0								Over operating bandwidth
Operational temperature range		°F (°C)	-40 to +140 (-40 to +60)								
DISTORTIONS											
Input level		dBmV	40.0								
Level repeatability		±dB	1.0								Maximum receiver RF level variation between transmitters
Return loss	Worst Case	-dB	10.0								
Single tone CNR		dB	50.0								CNR in 4 MHz bandwidth 9 dBmV @ input to station, using A8KQRR receiver
CTB	Worst Case	-dBc	64.0								Test uses 4T channels (T9-T13), using A8KQRR receiver
CSO	Worst Case	-dBc	62.0								Test uses 4T channels (T9-T13), using A8KQRR receiver

Confidential
 Information contained in this document is subject to change without notice.
 Revision Date:03/29/11

ACION 1002 Configuration Sheet

Customer: _____

Created By: _____ Order Date: _____

ORDERING MATRIX

October 31, 2011

Position	1	2	3	4	5	6	7	8	9	10	11	12	13	14	15
PART NUMBER	1	N	R												

3 **R** **BASIC CONFIGURATION**
R = Allows Dual Receivers (1 Tx)

4 **RECEIVERS**
0 = No Receiver
1 = Single Receiver
2 = Two Receivers

5 **TRANSMITTERS**
0 = No Transmitters
1 = Single Transmitter

6 **DIPLEX FREQUENCY SPLIT**
4 = 42/53
5 = 55/70
6 = 65/85
7 = 40/50
8 = 85/105

7 **OPTICAL CONNECTOR TYPE**
1 = SC/APC (Standard)
2 = SC/UPC
3 = FC/APC
4 = FC/UPC

8 **TRANSMITTER TYPE FP & DFB**
0 = None
D = Uncooled 1310 nm 1.0 mW FP
Y = Uncooled 1310 nm 1.0 mW FP W/ISOLATOR
H = Uncooled 1310 nm 2.0 mW FP W/ISOLATOR
B = Uncooled 1310 nm 3.0 mW DFB
J = Uncooled 1310 nm 1.0 mW DFB
C = Uncooled 1550 nm 2.0 mW DFB
E = Uncooled 1550 nm 2.0 mW DFB with WDM

TRANSMITTER TYPE CWDM
A = Uncooled 1471 nm DFB CWDM (2.0 mW)
G = Uncooled 1491 nm DFB CWDM (2.0 mW)
V = Uncooled 1511 nm DFB CWDM (2.0 mW)
L = Uncooled 1531 nm DFB CWDM (2.0 mW)
W = Uncooled 1551 nm DFB CWDM (2.0 mW)
M = Uncooled 1571 nm DFB CWDM (2.0 mW)
N = Uncooled 1591 nm DFB CWDM (2.0 mW)
T = Uncooled 1611 nm DFB CWDM (2.0 mW)
U = Uncooled 1551 nm DFB CWDM (2.0 mW) with WDM 1310/1550 nm

9 **STATION SLOPE**
0 = 0 dB @ 750 & 870 MHz
1 = 14.8 dB @ 870 & 17.2 @ 1002 MHz
2 = 12.9 dB @ 870 & 15.0 @ 1002 MHz
9 = 5.2 dB @ 870 & 6.0 @ 1002 MHz

10 **POWER SUPPLY INPUT TYPE (See Note 6)**
C = 40 TO 90 VAC (Cable powering)
L = 90 to 240 VAC (Mains Power Non-UL)
M = 90 to 240 VAC (Mains Power UL)

11 **POWER SUPPLY MAINS**
0 = NONE
1 = North America
2 = International/Europe
3 = Japan
4 = Australia
5 = Argentina
X = Custom (Contact Product Management)

12 **STATUS MONITORING (See Note 7)**
N = NONE (Standard)
M = Status Monitoring Upgradeable
C = Cheetah (Tollgrade)

13 **HOUSING TYPE**
0 = No Housing or Power supply
N = Normal (Standard)
C = Chromate Finish

14 **SURGE PROTECTION (See Note 8)**
A = Recommended Plug-in Sidactor
N = None

15 **CUSTOM**
Blank = Not custom
X = Determined by Product Management

NOTES:

- All ACION 1002 units are 1002 MHz.
- All ACION 1002 units will be shipped as a 2 port device. A conversion kit is available for a single port version. (P/N KIT-A1P1)
- All ACION 1002 units will be set up for max. gain of 48.7 dBmV on both ports (52.2 dBmV with jumper installed on single output version). The levels can be adjusted by the use of optional plug-in attenuator pads.
- All ACION 1002 units will be set up to the chosen slope (17.2 dB 1002 MHz is standard). Optionally, further adjusting of this slope can be accomplished with plug-in
- To complete 180 degree rotation of inner module, a power cord extension is required. (P/N 240314)
- The "M" version of the AC powered unit has an external UL listed 90-240 VAC to 24 VDC external transformer. The "L" version has a internal 90-240 VAC switching power supply and is not UL listed.
- The standard ACION 1002 node will not have the connectors required for upgrading the node in the field to have status monitoring.
- The optional surge protecting sidactor is only offered on the 40-90 VAC cable powered node.

Accessory & Spare Part Ordering Information:

The ACION 1002 ordering matrix provides the part number information to order the configured stations. This page contains the ordering information for the optional accessories and replacement or spare parts that can be ordered separately.

Part Number	Description
ACION 1000 Transmitters & Receivers (one Rx included with unit)	
XXX = Optical Connector Type (FC/UPC, SC/APC & SC/UPC)	
090667-01XXX	ACION 1002 Receiver 1002 MHz (One included with base unit)
090606-06XXX	ACION 1000/02 FP Transmitter 0.5 mW
090606-02XXX	ACION 1000/02 FP Transmitter 2.0 mW with Isolator
090607-03XXX	ACION 1000/02 DFB Uncooled, Isolated 1310 nm Transmitter 1.0 mW
090607-01XXX	ACION 1000/02 DFB Uncooled, Isolated 1310 nm Transmitter 3.0 mW
090607-02XXX	ACION 1000/02 DFB Uncooled, Isolated 1550 nm Transmitter 2.0 mW
090646-01XXX	ACION 1000/02 DFB CWDM Uncooled, Isolated 1471 nm Transmitter 2.0 mW
090646-02XXX	ACION 1000/02 DFB CWDM Uncooled, Isolated 1491 nm Transmitter 2.0 mW
090646-03XXX	ACION 1000/02 DFB CWDM Uncooled, Isolated 1511 nm Transmitter 2.0 mW
090646-04XXX	ACION 1000/02 DFB CWDM Uncooled, Isolated 1531 nm Transmitter 2.0 mW
090646-05XXX	ACION 1000/02 DFB CWDM Uncooled, Isolated 1551 nm Transmitter 2.0 mW
090646-06XXX	ACION 1000/02 DFB CWDM Uncooled, Isolated 1571 nm Transmitter 2.0 mW
090646-07XXX	ACION 1000/02 DFB CWDM Uncooled, Isolated 1591 nm Transmitter 2.0 mW
090646-08XXX	ACION 1000/02 DFB CWDM Uncooled, Isolated 1611 nm Transmitter 2.0 mW
WDM-01XXX	ACION 1000/02 WDM option
Linear Equalizers * = dB value	
LEQ870/*	Linear Equalizers 870 MHz 1.5 to 21.0 dB in 1.5 dB steps
LEQH1G/*	Linear Equalizers 1002 MHz 1 to 13 dB in 1.0 dB steps
Attenuators/Pads * = dB values	
JXP100-*	JXP Style Attenuators/Pads 1.0" long 0 to 20 in 0.5 dB steps
Plug-in Jumper, Splitter & Directional Couplers	
100355-01	Jumper (for single output port)
SDASPLTR3.5	Splitter, 3.5 dB, 1 GHz
SDADC7	Directional Coupler, 7 dB, 1 GHz
SDADC12	Directional Coupler, 12 dB, 1 GHz
AC Power Directors (For Cable 40-90 VAC version only)	
100818-01	AC Power Director (New Taller Version)
Reverse Path Rejection Filter	
RPRFLTR-8	Filter Reverse Rejection 8 MHz
Seizure Screw / RF Connector	
100633-01	Seizure Screw / RF Connector 15A
Power Supplies	
A1K-40-90PS-2	ACION 1000 40-90 VAC power supply (Version 2)
A1K-90-240PS	ACION 1000 90-240 VAC external power supply
Single Output Port Conversion Kit	
KIT-A1P1	ACION 1000 Single output port conversion kit (terminating pad, port plug and RF jumper)
Power Supply Extension Cable For RF Module Rotation	
240314	ACION 1000 Power Supply extension cable (for rotated RF module)
RF Test Probe	
100685-01	RF Test Probe 5.5"
TP-7504	RF Test Probe 1.57" (4 cm) Long
RF Test Adapter	
100677	Test Adapter for Test Probe to Seizure Screw (RF Connector)

