

ACION 3410 4 Driven-Output Optical Node 1002 MHz



The ACION 3410 four output Optical Node is a versatile platform with improved flexibility capable of reverse path segmentation.

Features

- Four driven output ports
- -20.0 dB directional coupler test points
- 15 amp power passing
- Plug-in bridger switching for managing the reverse path @ 0, -3.0, -6.0, -12.0 dB and open with active status monitoring (optional)
- Reverse path -20.0 dB test points for each port
- Separate attenuator control for each reverse path
- Plug-in equalizers and pads
- 1002 MHz housing platform
- Plug-in surge protection sidactor (optional)
- 4:1 configuration is field upgradeable to a 2:1 (X2) for reverse path segmentation
- Reverse path segmentable on the 2:1 (X2) configuration
- AM communications or Tollgrade (Cheetah) standard protocol status monitoring (optional)
- FP, DFB and CWDM transmitters available
- Redundant receiver (optional)
- Redundant transmitter (optional 4:1 only)
- 85% efficient 40/90 VAC switch-mode power supply with built-in Triac surge protection
- Dedicated 5-200 MHz reverse injection port (optional)

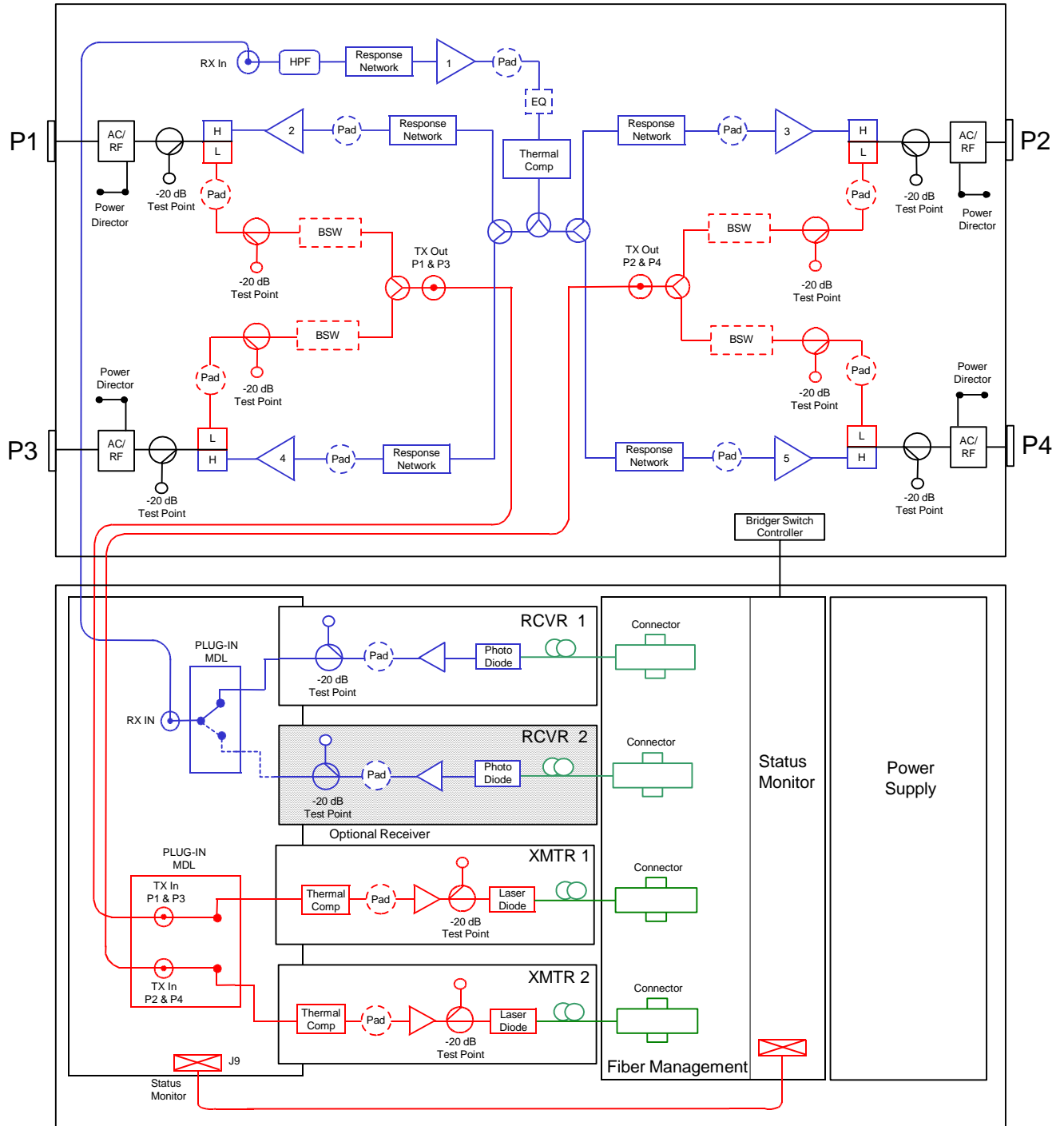

ACION 3410 Block Diagram (Reverse Segmentable Optical Node 1002 MHz)

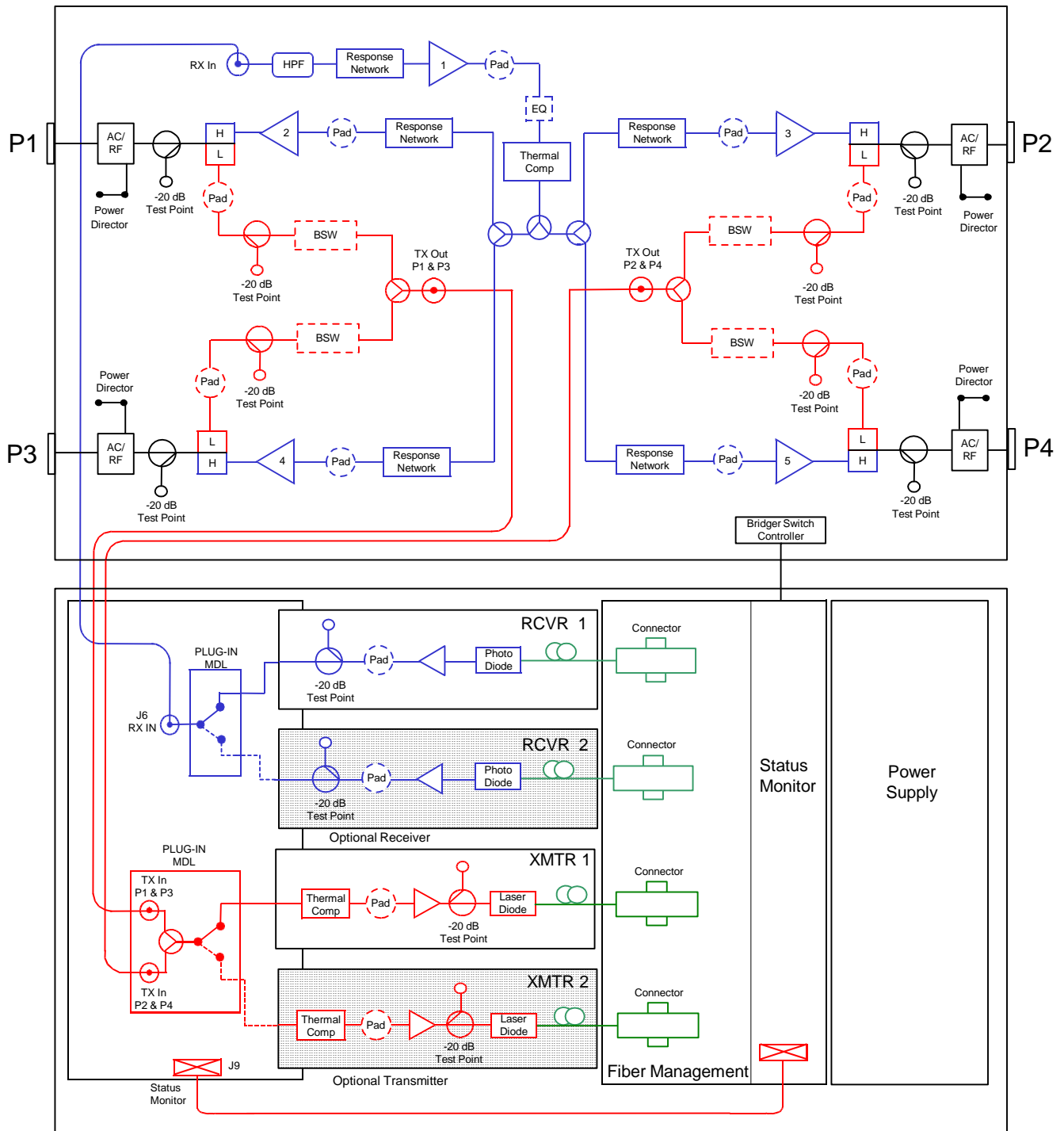

ACION 3410 Block Diagram (Reverse Non-Segmentable Optical Node 1002 MHz)

ACI Communications, Inc.			ACION 3410 4-Output (Reverse Segmentable 4 Output Optical Node 1002 MHz)				
STATION PARAMETERS							
	CONDITIONS	UNITS	SPECIFICATION				NOTES
Housing passband		MHz	5 to 1002				
Input current capacity	Any port, worst case	Amperes	15				
Frequency range		MHz	5 - 10	11 - 600	601 - 750	751 - 1002	
Hum modulation	Time domain @ rated current above	-dBc	55	65	60	55	
Station passband		MHz	54 to 1002				
Return loss	Worst case	-dB	17.0				Typical 18.0
Test Points							
Test point type	Directional coupler	N / A	DC				
Test point level(s)		-dB	20.0				
Test point accuracy	Forward TP	±dB	0.5				
Frequency range		MHz	5 to 40				
Test point accuracy	Reverse TP	±dB	0.5				
Frequency Range							
Station passband		MHz	54 to 1002				
Station flatness - feeder out		±dB	0.75				
Station Gain							
Gain - feeder	Minimum @ 1002 MHz	dB	31				
Gain control type		N / A	Plug-in pads				
Gain control range		dB	15.0				
Gain control steps	Pad value steps	dB	0.5				
Station Slope							
Slope control type	Linear equalizers	dB	Plug-in Equalizers				
Slope control range		dB	-20.0 to +13.0				
Slope control steps	Equalizer value steps	dB	1.0 linear steps				
Operational Specifications							
Operational level - feeders	@ 1002 MHz	dBmV	52.0				
Operational slope	@ 54 / 550 / 750 / 870 / 1002 MHz	dB	0 / 8.4 / 11.7 / 13.8 / 16.0				
Operational optical input range		dBm	-3 to +2				Recommended optical input level 0 dBm
Station Output Levels							
Distribution out	@ 54 / 550 / 750 / 870 / 1002 MHz	dBmV	36.0 / 44.4 / 47.7 / 49.8 / 52.0				@ -3 dBm input level 31.0 dB RF gain
Station Noise Figure - values for RF portion of node only. Complete values dependent on optical link.							
			* No slope	16.0 dB slope	* LEQ1= 0 dB		
Noise figure (NF)	@ 54 MHz	dB	9.5	16.0			
Noise figure (NF)	@ 550 MHz	dB	9.5	11.0			
Noise figure (NF)	@ 1002 MHz	dB	9.5	11.0			
Station Distortions - values for RF Portion of node only. Complete values dependent on optical link.							
550 MHz analog channel loading, 79 channels + 450 MHz digital channel loading, 256 QAM at -6 dBc relative to its associated visual carrier							
Reference levels	@ 54 / 550 / 750 / 870 / 1002 MHz	dBmV	36.0 / 44.4 / 47.7 / 49.8 / 52.0				
		N / A	Worst Case		Typical		
Composite Triple Beat (CTB)		-dBc	72		74		
Cross Modulation (XMOD)		-dBc	66		68		
Composite Second Order (CSO -)	(Vc +0.75 & -1.25 MHz only)	-dBc	73		75		
Composite Second Order (CSO +)	(Vc +1.25 MHz only)	-dBc	77		79		
Composite Intermodulation Noise (CIN)		-dBc	70		72		
Station Group Delay							
Group delay	Channel 2 (std)	nSec / 3.58 MHz	30		Typical 25		
Group delay	Channel 3	nSec / 3.58 MHz	16				
Group delay	Channel 4	nSec / 3.58 MHz	10				
Group delay	Channel 5 & >	nSec / 3.58 MHz	3				

Confidential
 information contained in this document is subject to change without notice.
 Revision date: 03/07/09

ACI Communications, Inc.			ACION 3410 4-Output (Reverse Segmentable 4 Output Optical Node 1002 MHz)		
REVERSE SPECTRUM:					
	CONDITIONS	UNITS	SPECIFICATIONS		NOTES
Reverse - General					
Station passband		MHz	5 to 42		
Station flatness		±dB	1.0		
Bridger switch control (optional)		-dB	0, 3.0, 6.0, 12.0 & open		
Reverse - Station Gain (RF section only)					
Configuration			4:1	2:1 (X2)	
Gain	Minimum	dB	*10.0	6.0	*for one TX Configuration
Gain control type		N / A	Plug-in pads		
Gain control steps	Pad value steps	dB	0.5		
Reverse - Station Input Levels					
RF station input to node for 40 dBmV @ Laser TP	Minimum	dBmV	17		
Reverse - Noise Figure					
Configuration			4:1	2:1 (X2)	
Station Noise Figure (w/EQ)		dB	16.5	12.0	
Reverse - Station Distortions @ 23 dBmV					
Composite Second Order (CSO)	6 NTSC channel loading	-dBc	75		
Composite Triple Beat (CTB)	6 NTSC channel loading	-dBc	80		
Cross Modulation (XMOD)	6 NTSC channel loading	-dBc	80		
Noise-to-Power Ratio (NPR)	Noise loading	dB	Typical >40.0 / 12.0		@ 10.0 dB optical loss (6.0 dB fiber +4.0 dB flat loss) @ -52.0 dBmV/Hz
Reverse - Station Group Delay					
Group delay	5 MHz	nSec / 1.5 MHz	36		
Group delay	7 MHz	nSec / 1.5 MHz	16		
Group delay	10 MHz	nSec / 1.5 MHz	4		
Group delay	35 MHz	nSec / 1.5 MHz	10		
Group delay	38.5 MHz	nSec / 1.5 MHz	25		
Power Requirements:					
Station configuration	2 RX + 2 TX over temperature range of -40°F to +140°F (-40°C to +60°C) @ 90 VAC				
Power requirements	Worst case	W	70		
AC Voltage					
Input ranges		VAC	40 - 90		
Current Draw (With 2 RX & 2 TX)					
@ 40 VAC	Maximum	A	2.25		
@ 50 VAC	Maximum	A	1.81		
@ 60 VAC	Maximum	A	1.56		
@ 70 VAC	Maximum	A	1.39		
@ 80 VAC	Maximum	A	1.26		
@ 90 VAC	Maximum	A	1.15		
Environmental					
Operating temperature		°F (°C)	-40 to +140 (-40 to +60)		
RF output stability over temperature		±dB	0.5		
Physical					
Dimensions (H X W X D)		In. (cm)	6.75 X 14.25 X 9 (17.15 X 36.20 X 22.86)		
Weight		lbs. (kg)	18.25 (8.28)		

Confidential
Information contained in this document is subject to change without notice.
Revision date: 03/07/09

ACION 3410 Configuration Sheet

Customer: _____

Created By: _____

Order Date: _____

ORDERING MATRIX

March 7, 2009

Position	1	2	3	4	5	6	7	8	9	11	11	12	13	14	15
PART NUMBER	3	K													

- | | |
|---|--|
| <p>3 <input type="checkbox"/> BASIC CONFIGURATION
 A = FWD 1:4 REV 4:1 nonsegmented TX and RX redundancy capable
 B = FWD 1:4 REV 2:1 (X2) segmented 2 transmitters installed RX redundancy capable
 C = Optical Upgrade Kit Only FWD 1:4 REV 4:1 nonsegmented TX and RX redundancy capable
 D = Optical Upgrade Kit Only FWD 1:4 REV 2:1 (X2) segmented 2 transmitters installed RX redundancy capable</p> <p>4 <input type="checkbox"/> DIPLEX FREQUENCY SPLIT
 4 = 42/53
 5 = 55/70
 6 = 65/85</p> <p>5 <input type="checkbox"/> OPTICAL CONNECTOR TYPE
 1 = SC/APC (Standard)
 2 = SC/UPC
 3 = FC/APC
 4 = FC/UPC</p> <p>6 <input type="checkbox"/> TRANSMITTER TYPE FP & DFB
 0 = NONE
 P = Uncooled 1310 nm FP (0.5 mW) W/O Isolator
 D = Uncooled 1310 nm FP (1.0 mW) W/O Isolator
 Y = Uncooled 1310 nm FP (1.0 mW) W/ Isolator
 H = Uncooled 1310 nm FP (2.0 mW) W/ Isolator
 B = Uncooled 1310 nm DFB (3.0 mW)
 C = Uncooled 1550 nm DFB (2.0 mW)
 E = Uncooled 1550 nm DFB (2.0 mW) with WDM (See Note 1) (4:1 only)
 J = Uncooled 1310 nm DFB (1.0 mW) W/Isolator</p> | <p>7 <input type="checkbox"/> RECEIVER REDUNDANCY
 1 = Not redundant
 2 = Redundant</p> <p>8 <input type="checkbox"/> TRANSMITTER REDUNDANCY (1:4 only)
 1 = Not redundant
 2 = Redundant</p> <p>9 <input type="checkbox"/> STATUS MONITORING
 0 = None
 A = AM Communications
 C = Cheetah (Tollgrade)</p> <p>10 <input type="checkbox"/> BRIDGER SWITCHING (See notes 2, 3 & 4)
 Requires status monitoring
 1 = No bridger switching
 2 = Bridger switching</p> <p>11 <input type="checkbox"/> HOUSING TYPE
 0 = Standard
 1 = Chromate</p> <p>12 <input type="checkbox"/> SURGE PROTECTION
 1 = Recommended plug-in sidactor
 2 = Triac (standard and included on 3410)</p> <p>13 <input type="checkbox"/> LOCAL INJECTION (See note 6)
 0 = Passive (standard)
 1 = Active (with gain and filters)</p> <p>14 <input type="checkbox"/> RETURN OPTICAL SPLITTER (See note 6)
 0 = None
 1 = One reverse optical splitter (Nonsegmented)</p> <p>15 <input type="checkbox"/>
 0 = None
 9 = 900 MHz Forward upper frequency
 G = 1002 MHz Forward upper frequency (16.0 dB Slope)
 R = ORX Discrete type
 X = Determined by Product Management</p> |
|---|--|

NOTES:

1. WDM configured as 1310 nm forward, 1550 nm reverse for single fiber solution (4:1 only)
2. Bridger switching can be configured at the factory (preferred) or upgraded in the field.
3. Status monitoring transponder is required for bridger switch functionality.
4. With no status monitoring transponder installed, the bridger switches default to minimum insertion loss.
5. 5-200 MHz reverse dedicated entry port (4:1 only)
6. Optical splitter for TX output

CWDM TRANSMITTER SOLD SEPARATELY

(Where XXX = connector type)

Part Number	Description
090700-01XXX	TRANSMITTER, DFB (CWDM) E-BAND 1431 nm 2.0 mW
090700-02XXX	TRANSMITTER, DFB (CWDM) E-BAND 1451 nm 2.0 mW
090650-01XXX	TRANSMITTER, DFB (CWDM) 1471 nm 2.0 mW
090650-02XXX	TRANSMITTER, DFB (CWDM) 1491 nm 2.0 mW
090650-03XXX	TRANSMITTER, DFB (CWDM) 1511 nm 2.0 mW
090650-04XXX	TRANSMITTER, DFB (CWDM) 1531 nm 2.0 mW
090650-05XXX	TRANSMITTER, DFB (CWDM) 1551 nm 2.0 mW
090650-06XXX	TRANSMITTER, DFB (CWDM) 1571 nm 2.0 mW
090650-07XXX	TRANSMITTER, DFB (CWDM) 1591 nm 2.0 mW
090650-08XXX	TRANSMITTER, DFB (CWDM) 1611 nm 2.0 mW

Contact factory for MUX/DEMUX options

