



## Drop Amplifiers



The ACI Communications Drop Amplifier line consists of house-type active devices that deliver superior performance up to 1 GHz in today's expanding RF telecommunications networks.

The Drop Amplifier provides additional gain at the customer premise when needed as a result of long drops, multiple TV outlets, or multiple service requirements.

The Drop Amplifier is available in one and four output, with GaAsFET technologies, and is configured for reverse path passive transmission. The one output version has a 15 dB output gain, and the four output version has a typical 8 dB output gain per port.

The Drop Amplifier allows very versatile deployment. To install, simply locate and mount the amplifier, and then connect the RF input cable and the RF output cable(s). Since the amplifier is a DC powered device, powering may be achieved in two different ways. It can either be powered directly in a co-located situation through an externally mounted transformer or it may be powered remotely by an externally mounted transformer via the cable through a power inserter at the TV set location.

### Features

- Two-way transmission through passive reverse
- 1 GHz bandwidths
- 15.0 forward gain on the one port, 8.0 dB gain on each of the four ports
- GaAsFET technologies
- Superior performance specifications for full channel loading at design bandwidth
- Low noise and excellent distortion performance
- Low power consumption
- Die-cast aluminum housing for excellent heat dissipation
- Perfect for both indoor and outdoor applications
- Remote or co-located powering capability
- 6 Kv combination wave surge protection on amplifier – all ports (IEEE587 category B3)
- 6 Kv combination wave surge protection on the transformer (IEEE587 category B3).
- High performance "F" connectors – SCTE compliant

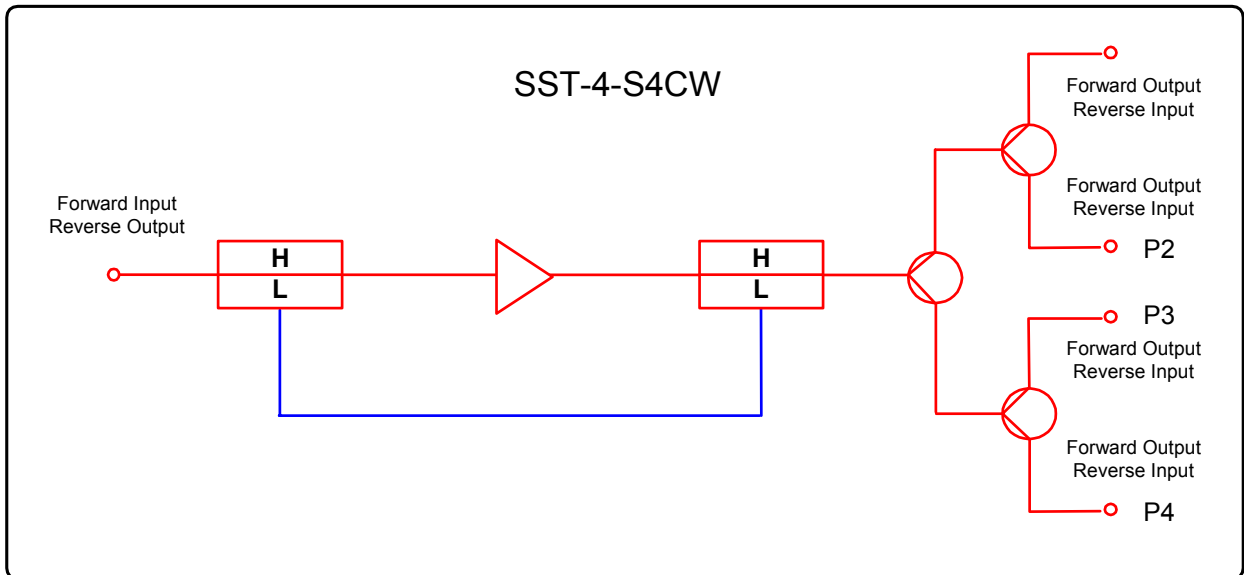
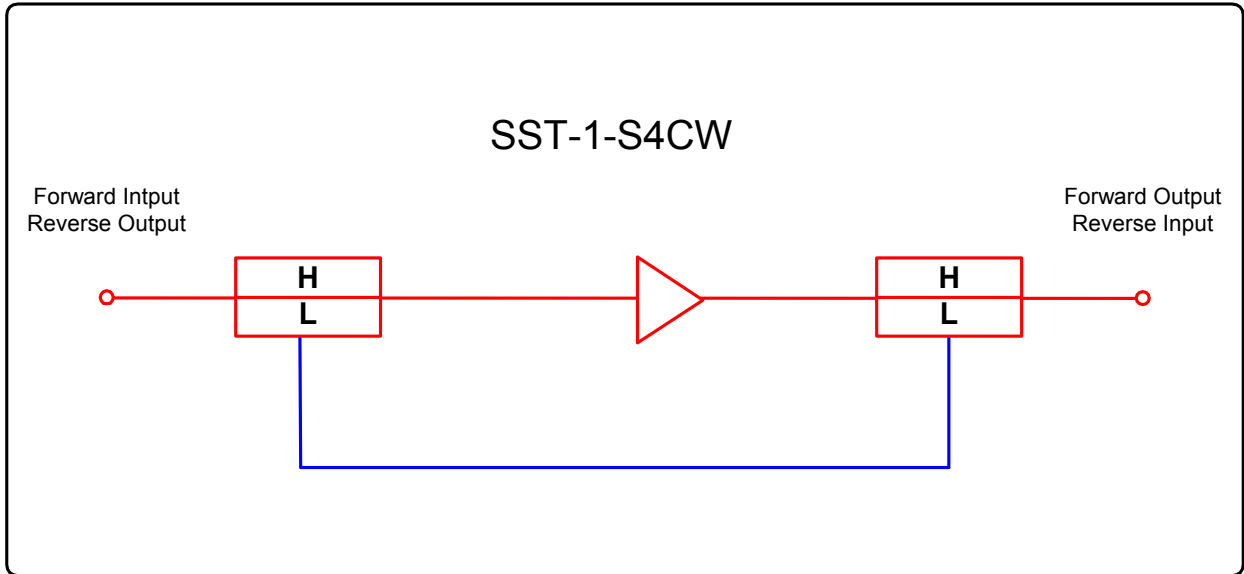

ACI Communications, Inc.,			Drop Amplifiers 1 & 4 Port		
STATION PARAMETERS:			1 PORT	4 PORT	
	CONDITIONS	UNITS	SPECIFICATIONS		NOTES
FORWARD		MHz	53 to 1000		
Gain		dB	15.0 ±0.5	8.0 ±0.5	
Flatness		±dB	0.5	0.5	
Slope		±dB	1	1	
Output impedance		ohm	75	75	
Return loss	Worst case / typical	dB	18 / 20	18 / 20	
Noise figure	Worst case within specified bandwidth	dB	3.5	5.0	
RF port-to port isolation		dB	NA	25	
RF port-to power port isolation		dB	≥55	≥55	
Group Delay (n = Sec / 3.58 MHz)					
Channel 2-5		ns	<20	<20	
Channel 6 & up		ns	<5	<5	
Power consumption		Watts	3	3	
Reverse (Passive)		MHz	5 to 42		
Insertion loss	Max	dB	1	8	
Return loss	Worst case / typical	dB	18 / 20	18 / 20	
Flatness		±dB	0.5	0.5	
Group Delay (n = Sec / 1.5 MHz)					
5 to 40 MHz		ns	<20	<20	
550 MHz analog channel loading, 79 channels +320 MHz digital channel loading, 256 QAM at -6dBc relative to its associated visual carrier					
Station Output Levels					
Levels out		dBmV	25	18	
Station Distortions (Worst Case)					
Composite Triple Beat (CTB)		-dBc	75	75	
Cross Modulation (XMOD)		-dBc	75	75	
Composite Second Order (CSO)		-dBc	65	65	
HUM Modulation		≥dB	80	80	
Physical Information					
Mechanical F-port seal		psi	10	10	
Operating temperature range		°F	-40 to +140	-40 to +140	
RFI / EMI isolation		dB	≥120 dB		
Surge protection	All Ports IEEE C62.41-1991 Category B3 6 KV, 2 KA	KV	6	6	
Dimensions	Height x Width x Depth	in. (cm)	5.0 x 4.8 x 1.5 (132.7 x 12.1 x 3.8)		
Weight	With transformer	lbs. (kg)	2.2 (1.0)		

Confidential  
 Information contained in this document is subject to change without notice.  
 Revision Date: 07/23/04

## Configuration Worksheet

### SST Combo Wave Configuration Sheet

Customer: \_\_\_\_\_

Created By: \_\_\_\_\_ Order Date: \_\_\_\_\_

#### ORDERING MATRIX

June 7, 2005

Position	1	2	3	4	5	6	7	8	9	10	11	12	13
MODEL NUMBER	S	S	T	-		-	S		C	W	-		

1-2-3

MODEL

SST - Drop Amplifier

12-13

TRANSFORMER OPTIONS

Blank = SST amplifier only

01 = W/120 VAC / 12 VDC transformer

02 = W/230 VAC / 12 VDC transformer

5

NUMBER OF OUTPUT PORTS

1 = 1 Output

4 = 4 Outputs

OPTIONAL ACCESSORIES (sold separately)

7-8

FREQUENCY SPLIT

S4 = Subsplit (42 - 53)

S6 = Supsplit (65 / 85)

Part Number

PI - 30

120 V - U

230 V - A

Description

Cable power inserter 12 - 30 VDC (F ports)

Transformer 120 VAC / 12 VDC (F ports)

Transformer 230 VAC / 12 VDC (F ports)

#### NOTES:

#### Electrical Safety (North American example)

The wall mounted (Electrical outlet) power supply requires 120VAC, 60Hz, 1-ampere maximum input power source, with proper ground. Please refer to local electrical codes. The amplifier requires 12VDC at 300ma. The power transformer should be UL type 2 rated.

It is recommended that the power pack not be installed on a circuit that is shared with such electrical noise sources as motors, starting solenoids, toasters, or equipment that operates intermittently with high starting currents.

